



非洲鼓金字塔（三）

飞手 2020 年编写

Call

Break 前奏，Dunun 同步以下

拍手唱 Djamana, kenkeni 伴奏







Dan

Dan 是一个草药医师表演的面具舞，来自几内亚丛林中的 foro 地区，传统上是用 tariba、jabara、kirin 等其他乐器演奏的，这些 djembe 伴奏是通过 kirin（象木鱼的乐器）演变来的。这个曲子的三个 dunun 是立在地上三个人分别演奏的。

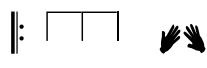
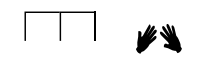
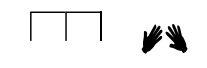

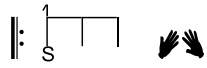
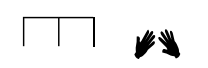
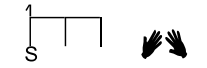

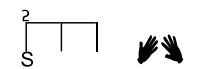



（歌曲选自 Djamana，意思是 djembe 世界和 dunun 世界）

Djamana djembe djamana,Djamana djembe djamana a.

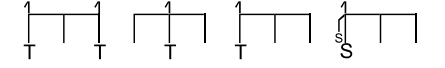

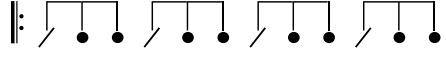
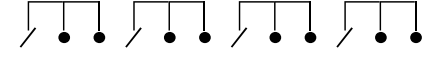

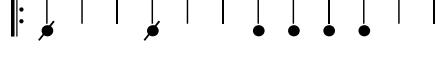
Djamana dunun djamana,Djamana dunun djamana a.

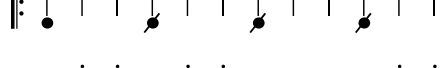
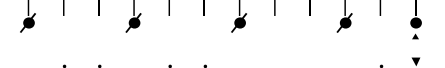
					:	:
					:	:
					:	:
na	djembe	djama	na		Djama	
na	djembe	djama	na	a	djama	

Call

					
	:				:
	:				:
	:				:

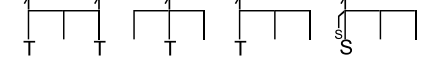
唱之后先接只有 Dunun 节奏，再分别接下面 Djembe 节奏

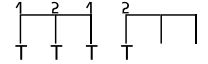
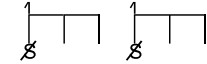
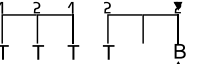
							
	:						:

| 1 2 1 2 1 2 1 2 1 2 | 1 2 1 2 1 2 1 2 1 2 |

Roll

| 1 2 1 2 1 2 1 2 1 2 | 1 2 1 2 1 2 1 2 1 2 |

接 Dunun 和 Djembe 基本节奏

1 | 1 2 1 2 1 2 1 2 1 2 | 2 1 2 1 2 1 2 1 2 1 2 |

Roll-Call 后直接 Solo

Solo

| 1 2 1 2 1 2 1 2 1 2 | 1 2 1 2 1 2 1 2 1 2 | :|| 2x

| 1 2 1 2 1 2 1 1 1 1 | 1 1 1 1 1 1 1 1 |
 | B S S B T T B S S | T T T T T T T S |
 ||: 1 2 1 2 1 2 1 2 1 2 | 1 2 1 2 1 2 1 2 | 2x
S B T T S S S S S S	S B T T S S S S S S
1 2 1 2 1 2 1 2 2	1 1 1 1 1 1 1 1
S B T T S S S S	T T T T T T T S
	: 1 1 1 1 2 1 2 1 1 1
B T T T B B	B T T T B B
	: 1 1 1 1 2 1 1 1 2 1 2
B S S S S S S	B S S S S S S
1 1 1 1 2 1 1 1 2 1 2	1 1 1 1 2 1 1 1 2 1 2
B S S S S S S	B S S S S S S
	: 1 1 1 1 2 1 1 1 2 1 2
B T T T S T T S T T S T T S	S T T S T T S T T S
	: 1 1 1 1 2 1 1 1 2 1 2
B S S S S S S	B S S S S S S
	: 1 1 1 1 2 1 2 1 1 1 1
B T T T B B	B T T T B B
1 1 1 1 1 1 1 1	
B S S S S S S	

空之后打 Call 接下面连接处

||: 1 2 1 2 1 2 1 1 1 1 | 1 2 1 1 1 1 1 1 | 4x
 | T T T T T T T T | T T S S S S |
 ||: ● ● ● ● ● ● ● ● | ● ● ● ● ● ● ● ● | 4x
 | ● ● ● ● ● ● ● ● | ● ● ● ● ● ● ● ● |
 ||: 1 2 1 1 2 1 2 1 1 1 | 1 2 1 1 2 1 2 1 1 1 | 2x
 | S S S S S S S S | S S S S S S S S |
 ||: ● ● ● ● ● ● ● ● | ● ● ● ● ● ● ● ● | 2x
 | ● ● ● ● ● ● ● ● | ● ● ● ● ● ● ● ● |
 ||: 1 2 1 2 1 2 1 2 1 2 | 1 2 1 1 2 1 2 1 1 1 | 4x
 | T T S T T S T T T S T T T S | T T B B B |
 ||: ● ● ● ● ● ● ● ● | ● ● ● ● ● ● ● ● | 4x
 | ● ● ● ● ● ● ● ● | ● ● ● ● ● ● ● ● |
 ||: 1 2 1 2 1 2 1 2 1 2 | 1 2 1 1 2 1 2 1 1 1 | 4x
 | T T S S S S S S S S | T T B B B |
 ||: ● ● ● ● ● ● ● ● | ● ● ● ● ● ● ● ● | 4x
 | ● ● ● ● ● ● ● ● | ● ● ● ● ● ● ● ● |

Dunun 节奏渐弱后接 Sorsornet 清唱

Sorsornet

这首曲子来自几内亚西部的巴加族（Baga）。Sorsornet 面具被认为是好运气的象征，平时这个面具并不在村庄里保管，而是放在森林里，但有时也会出现在村庄里。这个面具被认为是村庄的保护神。它有规劝人们戒除陋习、积德行善的作用。如果一个村庄拥有了自己的面具，当别人想要得到村庄的秘密时，这个面具会对其进行干扰。如果有人被疾病或不能生育等问题困扰时，会求助于面具的监管者，让他找出面具，帮人们渡过难关。当面具出现村庄里的时候，人们就会演奏 Sorsornet，并且面具将在村庄里游行。如今这首歌曲非常大众化和流行。这是年轻女孩对母亲表达感恩的一首歌，通常在月光下演唱。歌词的意思：

谢谢你啊，母亲，给我好品格。不用担心，我会很快跟我的丈夫在一起了。

M'baraka felenkoee,N'doro mamuna komna.

M'baraka felenko n'gayo n' gaa,N'doro mamuna komna.

n'tapelindoee,n'tapelindoee,n'tapelindoee zinezagona banganiee.

Call

The musical notation for the call consists of several systems. Each system begins with an icon representing an instrument: a kora, a balafon, a djembe, a talking drum, and a kora. The notation uses stems with flags to indicate rhythm and dots for pitch. Fingerings (1, 2) are indicated above notes. The call is divided into three parts, labeled 1, 2, and 3, each with its own set of rhythmic patterns.

m'barake felen ko ee

m'baraka felen ko n'ga yo n' gaa

n'tapelin do ee

n'tapelin do ee zinezagona

n'doromamunakom na

n'doro mamuna kom na

n'tapelindo ee

ban ga niee

Break

1

 | 1 2 1 | 1 2 1 | 2 1 1 | 2 1 1 | | 1 2 1 | 1 2 1 | 1 2 1 | 1 2 1 | |

 | * * * | * * * | * * * | * * * | | * * * | * * * | * * * | * * * | |

2

 | 1 2 1 | 1 2 1 | 2 1 1 | 2 1 1 | | 1 2 1 | 1 2 1 | 2 1 1 | 2 1 1 | |

 | 1 2 1 | 1 2 1 | 1 2 1 | 1 2 1 | |

3

 | 1 2 1 | 1 2 1 | 2 1 1 | 2 1 1 | | 1 2 1 | P | P | P | P | |

 | * * * | * * * | * * * | * * * | | * * * | * * * | * * * | * * * | |

 | 1 2 1 | P | P | P | P | | 1 2 1 | P | P | P | P | |

 | * * * | * * * | * * * | * * * | | * * * | * * * | * * * | * * * | |

 | 1 2 1 | P | P | P | P | | 1 2 1 | 1 2 1 | 2 1 1 | 2 1 1 | |

 | * * * | * * * | * * * | * * * | | * * * | * * * | * * * | * * * | |

 | 1 2 1 | 1 2 1 | 1 2 1 | 1 2 1 | |

 | * * * | * * * | * * * | * * * | |

4

 | :| 1 2 1 | 2 1 1 | 1 2 1 | 2 1 1 | | 1 2 1 | 2 1 2 | 1 2 1 | 2 1 2 | :| **3x**

 | 1 2 1 | 2 1 1 | 1 2 1 | 2 1 1 | | 1 2 1 | 1 2 1 2 | 1 2 1 2 | 1 2 1 2 | |

 | :| 1 2 1 | 2 1 2 | 1 2 1 | 2 1 2 | | 1 2 1 | 2 1 2 | 1 2 1 | 2 1 2 | :| **2x**

 | 1 2 1 | 2 1 2 | 1 2 1 | 2 1 2 | | 1 2 1 | 2 1 2 | 1 2 1 | 2 1 2 | |

 | 1 2 1 | 2 1 2 | 1 2 1 | 1 2 1 | | 1 2 1 | 2 1 2 | 1 2 1 | 2 1 2 | |

5

 | 1 2 1 | 1 2 1 | 2 1 1 | 2 1 1 | | 1 2 1 | 1 2 1 | 2 1 1 | 2 1 1 | |

Kenkeni 先进，然后 Sangban，然后 Dununba

Call 之后 Dunun 同步下面中音，最后领奏打 Call 时其他鼓停止

Call 之后进下面节奏，Dununba 基本节奏和同步第 2 小节高音，

Call 之后接下面节奏，Dunun 同步下面中音

接下面 Djembe 节奏，Dunun 基本节奏

Call 之后接下面 Djembe 节奏，Dununba 同步下面低音，Call 时其他鼓停止

Yankadi

Yankadi 是几内亚西南部苏苏族的诱惑之舞，起源于古代的塞拉利昂，主要在女约会的时候跳，也在部落里的节庆、婚礼以及其他庆典里跳。Yankadi 是慢节奏的舞蹈（传统上这种舞蹈是大伙围成一个圆圈来跳的，但现在为了表演的方便舞者要面对观众来跳）。开始跳舞的时候，男孩和女孩面对面排成两排，用眼神交流，做出引诱的动作，以及接触舞伴的手心。随着舞蹈的进行，其中一个男人会把象征爱恋的围巾放在一个女孩面前，只要一放好围巾就会响起作为信号的哨子声。

歌词的意思是祈求世界和平。

Du ni ya ma ha ta ma du ni ya ma.

Ai weng ge weng po li di mei du ni ya ma.

La guinea fu ri ye du ni ya ma.

China fu ri ye du ni ya ma.

Senegal fu ri ye du ni ya ma.

Ai weng ge weng po li di mei du ni ya ma.

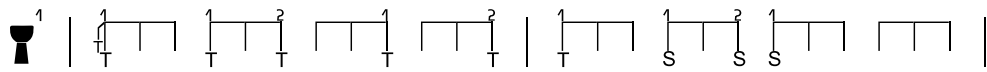
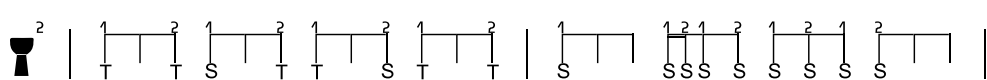

Call

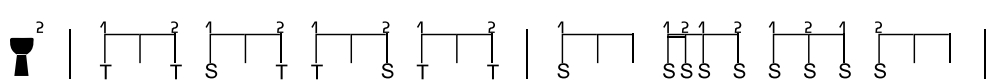
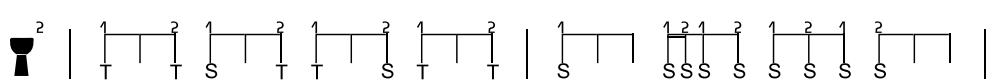

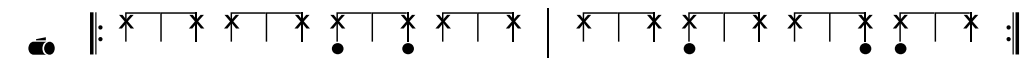
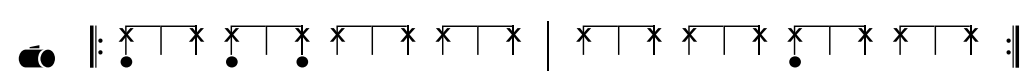
1  |  |

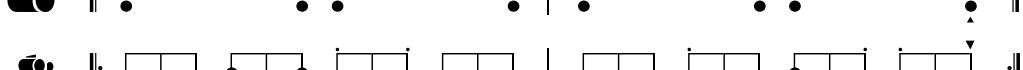

2  |  |

 ||:  ||:

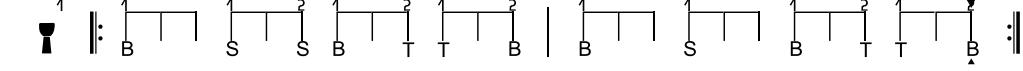
 ||:  ||:

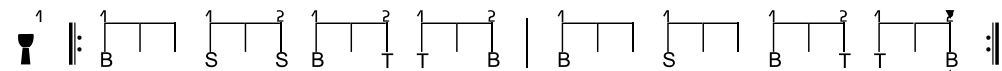

 ||:  ||:

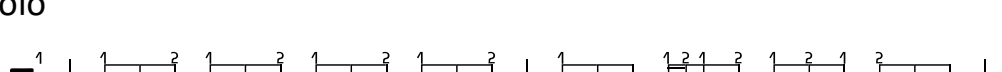

 ||:  ||:

1  ||:  ||:

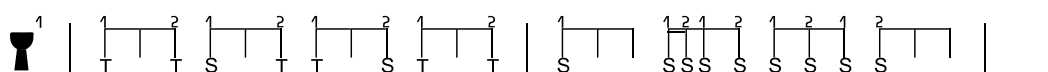
2  ||:  ||:

Solo

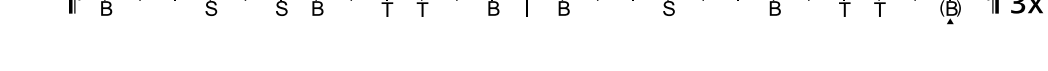
1  |  |

 ||:  ||: 3x

2

3

4

5

接下面 Djembe 节奏和曲目 Somba Koro 的 Dununba 齐奏

嘿

Call 之后接 Break 和清唱

Somba Koro

Gidamba (Gidanba Dyidanba Kidamba) 是传统的马林克族节奏。Somba koro 这首歌曲来自几内亚 Hamama 地区，歌词中 Nankuma 是一个男孩的名字，Somba koro 是女贼的意思。这首歌说的是母亲是谁也无法替代的，不管她长得如何，或者她做错什么，我们都要试着去接受。这首曲子可以配不同的歌词（后半部分是另一首歌曲）来演唱，在很多场合都可以表演。

Nankuma i na bara na,mo na li i na di.

I na bara ke,Dyulu ta la di mo na li i na di.

Nankuma i na bara na,mo na li i na di.

I na bara ke,somba koro di mo na li i na di.

Nankuma i na bara na,mo na li i na di.

I na bara ke,Dyalan ba koro di mo na li i na di.

Nankuma i na bara na,mo na li i na di.

I na bara ke,somba koro di mo na li i na di.

Call

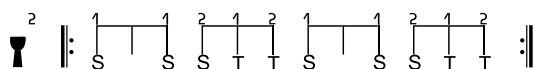
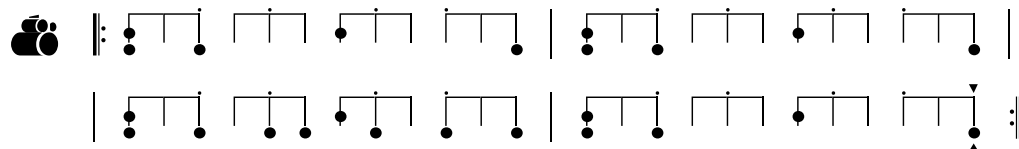
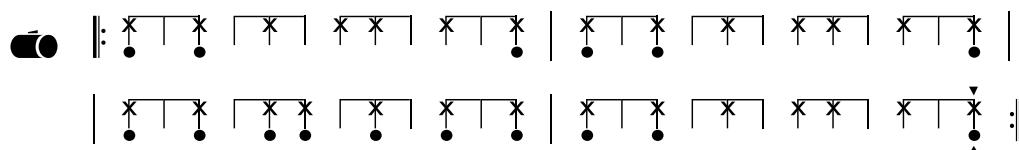
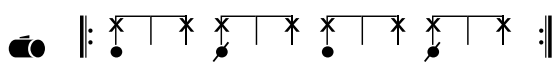
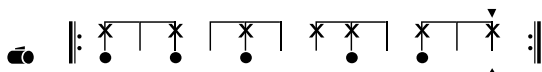
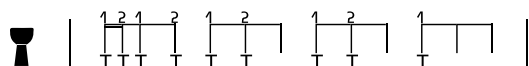

Break

Two lines of musical notation. The first line starts with a horn icon and contains four measures of notes with stems, each marked with a '1' above and an 'S' below. The second line contains four measures of notes with stems, each marked with an 'X' above and a dot below.

接基本节奏和 Roll-Call-Solo

Solo

Two horn icons labeled 1 and 2. Horn 1 has two lines of notation. The first line has four measures of notes with stems, each marked with a '1' above and a '2' below. The second line has a repeat sign followed by a sequence of notes and rests, ending with a double bar line and '4x'. Horn 2 has three lines of notation. The first line has four measures of notes with stems, each marked with a '1' above and a '2' below. The second line has a sequence of notes and rests, ending with a double bar line and '4x'. The third line has a sequence of notes and rests, ending with a double bar line and '4x'.

接 Call-Roll-Call-Break

Break

Two lines of musical notation. The first line starts with a horn icon and contains four measures of notes with stems, each marked with a '1' above and an 'S' below. The second line contains four measures of notes with stems, each marked with an 'X' above and a dot below.

接基本节奏和打鼓唱和 Roll-Call-Solo

A single line of musical notation starting with a repeat sign, followed by a sequence of notes and rests, ending with a double bar line and '4x'.

Nan ku ma i na ba ra na mo na li na di
I na ba ra ke somba ko ro di mo na li na di

Solo

Two horn icons labeled 1 and 2. Horn 1 has two lines of notation. The first line has four measures of notes with stems, each marked with a '1' above and a '2' below. The second line has a repeat sign followed by a sequence of notes and rests, ending with a double bar line and '4x'. Horn 2 has three lines of notation. The first line has four measures of notes with stems, each marked with a '1' above and a '2' below. The second line has a sequence of notes and rests, ending with a double bar line and '4x'. The third line has a sequence of notes and rests, ending with a double bar line and '4x'.

2

Roll

||: T S S S S S T T S S S S (S) (T) || 3x

||: * * * * * || 3x

接下面清唱

Na bai lai lu,nie nie so lai v.ai ya ai ya.
 Na bai lai lu,nie nie so lai v.ai ya ai ya.
 Na bai lai lu,nie nie so lai v.ai ya ai ya.

Ba ga lai lu,nie nie so lai v.ai ya ai ya.
 Ba ga lai lu,nie nie so lai v.ai ya ai ya.
 Ba ga lai lu,nie nie so lai v.ai ya ai ya.

A a,nie nie so lai v.ai ya ai ya.
 A a,nie nie so lai v.ai ya ai ya.
 A a,nie nie so lai v.ai ya ai ya.

Call

接基本节奏和自由 Solo-Roll-Call-Break

Break

接基本节奏和打鼓唱和 Roll-Call-Solo













bai lai lu nienieso lai v ai ya ai ya na
 ga lai lu nienieso lai v ai ya ai ya ba
 a nienieso lai v ai ya ai ya a

Solo





| 1 2 1 1 2 1 2 1 2 | 1 2 1 1 2 1 2 1 2 |
 | T S S S T S S B S S | T S S S T S S B S S |
 | 1 2 1 1 2 1 2 |
 | T S S S T S S B |

接 Call-Roll-Call-Break

Break

 | 1 1 1 1 1 1 1 1 | 1 1 1 1 1 1 1 1 |
 | S S S S S S S S | T T T T T T T T |
 | X X X X X X X X | X X X X X X X X |
 | S S S S S S S S | S S S S S S S S |
 | 1 2 1 2 1 2 1 2 | 2 1 1 2 1 2 1 2 |
 | B T T S S S S B T T | S S T T S S B T T |
 | X X X X X X X X | X X X X X X X X |
 | S S S S S S S S | S S S S S S S S |
 | 2 1 1 2 1 2 1 2 | 2 1 1 2 1 2 1 2 |
 | S S T T S S B T T | S S S S S S B T T |
 | X X X X X X X X | X X X X X X X X |
 | S S S S S S S S | S S S S S S S S |
 | 2 1 2 1 2 1 2 1 | 2 1 2 1 2 1 2 1 |
 | S T T T S T T T S S S B T T | S S S S S S B T T |
 | X X X X X X X X | X X X X X X X X |
 | S S S S S S S S | S S S S S S S S |
 | 2 1 2 1 2 1 2 1 | 2 1 2 1 2 1 2 1 |
 | S T T T S T T T S S S B T T | S S S S S S B T T |
 | X X X X X X X X | X X X X X X X X |
 | S S S S S S S S | S S S S S S S S |
 | X X X X X X X X | X X X X X X X X |
 | S S S S S S S S | S S S S S S S S |
 | X X X X X X X X | X X X X X X X X |
 | S S S S S S S S | S S S S S S S S |

Call

 | 1 1 2 1 2 1 2 1 | 1 2 1 2 1 2 1 2 |
 | S S T T T T T T B T T | S S S S S S S S |
 | X X X X X X X X | X X X X X X X X |
 | S S S S S S S S | S S S S S S S S |
 | 1 1 1 1 1 1 1 1 |
 | T T T T T T T T |
 | X X X X X X X X | X X X X X X X X |
 | S S S S S S S S | S S S S S S S S |

接 Sangban 牛铃

Soli

Soli (或者叫 Soli rapide), 这个是快版的 Soli, 还有一个慢版的 Soli, 叫做 Soli lente。慢版的老年人也可以跳舞。Soli 是几内亚马林克族的节奏, 一般伴随着成人礼的进行来演奏, 在成人礼开始的三个月前, 这个节奏已经开始演奏了。在仪式开始的前一晚, 节奏的演奏达到顶点, 男人和女人们都在跳舞。

(歌曲选自 Soli lente, 歌词大意: 起来吧, 孩子的妈妈, 是时候去演奏 Soli 了。)

Aiti iwuliba, dembati itiwuliba, soli bara se.

Aiti iwuliba, aiti iwuliba, soli bara se.

Call

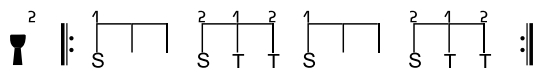
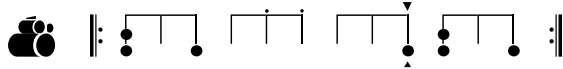
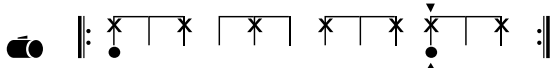
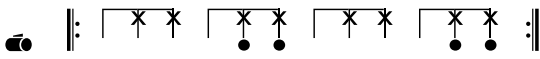
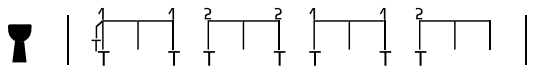

Sangban-Kenkeni-Dununba, 箭头处开始唱 Soli lente

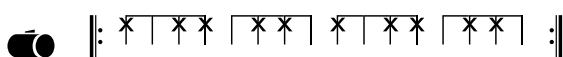

Ai ti iwuli

ba demba ti it iwuliba

so li bara se Ai ti iwuli

ba ai ti iwuliba

so li bara se

Break

 | 1 2 1 2 1 2 1 2 2 | 1 1 1 1 2 1 |
 T T S T T S T T S S B | S S S S S S S |

 | | | | | * | * * * * * |
 | | | | | | | | |

 | 1 2 1 2 1 2 1 2 2 | 1 1 1 1 2 1 |
 T T S T T S T T S S B | S S S S S S S |

 | | | | | * | * * * * * |
 | | | | | | | | |

 | 1 2 1 2 1 2 1 2 2 | 1 1 1 1 2 1 |
 T T S T T S T T S S B | S S B S S B |

 | | | | | * | * * * * * |
 | | | | | | | | |

 | 1 1 1 1 1 2 1 2 | 1 1 2 1 2 1 2 |
 S S S S S S S | T T T T T T T |

 | * * * * * | | | | | | | |
 | | | | | | | | |

Solo

¹  | 1 1 2 1 1 2 1 2 | 1 1 2 1 2 1 2 |
 S T S T S T S | S T S T S T S |

| 1 1 2 1 2 1 2 1 2 | 1 1 2 1 2 1 2 1 2 |
 S T S T S T S | T T T T T T T |

²  | 1 1 2 1 2 1 2 1 2 | 1 1 2 1 2 1 2 1 2 |
 S S S T T S S T T | S S S T T S S T T |

| 1 1 2 1 2 1 2 1 2 | 1 1 2 1 2 1 2 1 2 |
 S S S T T S S | T T T T T T T |

³  | 1 2 1 2 1 2 1 2 | 1 2 1 2 1 2 1 2 |
 B S S S B S B S | B S S S B S B S |

| 1 2 1 2 1 2 1 2 | 1 1 2 1 2 1 2 1 2 |
 B S S S B S S | T T T T T T T |

⁴  | 1 2 1 2 1 2 1 2 | 1 2 1 2 1 2 1 2 |
 B T T S B T T S | S S S S S S S |

| 1 1 2 1 2 1 2 1 2 | 1 1 2 1 2 1 2 1 2 |
 B T T S B S S | T T T T T T B T T |

⁵  | 1 2 1 2 1 2 1 2 | 1 2 1 2 1 2 1 2 |
 B T T B T T B T T | B T T B T T B T T |

| 1 1 2 1 2 1 2 1 2 | 1 1 2 1 2 1 2 1 2 |
 B S B S B S B S | B S B S B T T |

| 1 2 1 2 1 2 1 2 | 1 2 1 2 1 2 1 2 |
 B T T B T T B T T | B T T B T T |

| 1 1 2 1 2 1 2 1 2 | 1 1 2 1 2 1 2 1 2 |
 B S B S B S S | T T T T T T T |

|| 3x

6  :| 1 2 1 2 1 2 1 2 1 2 | 1 2 1 2 1 2 1 2 | 1 2 1 2 1 2 1 2 | 1 2 1 2 1 2 1 2 :| 3x

| 1 2 1 2 1 2 1 2 1 2 | 1 2 1 2 1 2 1 2 1 2 | 1 2 1 2 1 2 1 2 1 2 | 1 2 1 2 1 2 1 2 1 2 |

7  :| 1 2 1 2 1 2 1 2 1 2 | 1 2 1 2 1 2 1 2 1 2 | 1 2 1 2 1 2 1 2 1 2 | 1 2 1 2 1 2 1 2 1 2 :| 3x

| 1 2 1 2 1 2 1 2 1 2 | 1 2 1 2 1 2 1 2 1 2 | 1 2 1 2 1 2 1 2 1 2 | 1 2 1 2 1 2 1 2 1 2 |

空之后接 Kenkeni-Dununba-Sangban-Call-Break-djembe1

 :| 1 2 1 2 1 2 1 2 1 2 | 1 2 1 2 1 2 1 2 1 2 :|

 :| 1 2 1 2 1 2 1 2 1 2 | 1 2 1 2 1 2 1 2 1 2 :|

 :| 1 2 1 2 1 2 1 2 1 2 | 1 2 1 2 1 2 1 2 1 2 | 1 2 1 2 1 2 1 2 1 2 | 1 2 1 2 1 2 1 2 1 2 :|

1  :| 1 2 1 2 1 2 1 2 1 2 :|

2  :| 1 2 1 2 1 2 1 2 1 2 :|

3  :| 1 2 1 2 1 2 1 2 1 2 :|

 :| B 1 S B 2 T S B 1 S B 2 T S B 1 S B 2 T S :|

 :| 1 2 1 2 1 2 1 2 1 2 | 1 2 1 2 1 2 1 2 1 2 | 1 2 1 2 1 2 1 2 1 2 | 1 2 1 2 1 2 1 2 1 2 :| 4x

Roll-Call (Dununba 节奏第 4 小节进 Roll)

 :| 1 2 1 2 1 2 1 2 1 2 | 1 2 1 2 1 2 1 2 1 2 | 1 2 1 2 1 2 1 2 1 2 | 1 2 1 2 1 2 1 2 1 2 |

| 1 2 1 2 1 2 1 2 1 2 | 1 2 1 2 1 2 1 2 1 2 | 1 2 1 2 1 2 1 2 1 2 | 1 2 1 2 1 2 1 2 1 2 |

Break (Kenkeni 同步高音, Sangban+Dununba 同步低音)

 :| 1 1 1 1 1 1 1 1 1 1 | 1 1 1 1 1 1 1 1 1 1 | 1 1 1 1 1 1 1 1 1 1 | 1 1 1 1 1 1 1 1 1 1 :| 2x

| 1 1 1 1 1 1 1 1 1 1 | 1 1 1 1 1 1 1 1 1 1 | 1 1 1 1 1 1 1 1 1 1 | 1 1 1 1 1 1 1 1 1 1 |

 :| 1 2 1 2 1 2 1 2 1 2 | 1 2 1 2 1 2 1 2 1 2 | 1 2 1 2 1 2 1 2 1 2 | 1 2 1 2 1 2 1 2 1 2 |

| 1 2 1 2 1 2 1 2 1 2 | 1 2 1 2 1 2 1 2 1 2 | 1 2 1 2 1 2 1 2 1 2 | 1 2 1 2 1 2 1 2 1 2 |

||: || 同时进 Dunun 节奏

Solo

¹

||: || 4x

²

||: || 4x

³

||: || 4x

Djaa 2

Djaa 是一种马林克节奏，和其他很多节奏一样，是从女人的拍手发展而来。跳这个舞时，男女们分别围成两个半圈，面对彼此。这个舞很热辣，一般跳这个舞时，已经是活动的高潮了。Djaa 2 是指来自 Kouroussa 地区的 Djaa。

A you a you.

Jia ma ba la bo, bin na yi da lie da a

||: x x x x x | x B x x x ||: x 拍手

A you a you jia ma ba la
bo bin na yi da lie da a

||: S T S T S T S T | S T S T S T S T ||

Call

👤 | 1 2 1 2 | 1 2 | 1 2 | 1 |

👤 ||: * * | * * | * * | * * | | * * | * * | * * | * * | :|

👤 ||: * * | * * | * * | * * | | * * | * * | * * | * * | :|





👤 ||: * * | * * | * * | * * | | * * | * * | * * | * * | :|

👤 ||: * * | * * | * * | * * | | * * | * * | * * | * * | :|

1 👤 ||: S T S T S T S T | :|



2 👤 ||: S T S T S T S T | :|

Break (Dunun fola 后)

 | 1 2 | 1 2 | 1 | 1 2 | | 1 2 | 1 | 1 2 | 1 2 | |
 | * * | * * | * | * * | | * * | * | * * | * * | |
 | 1 | 1 2 | 1 2 | 1 | |
 | * | * * | * * | * | |

 | 1 2 | 1 1 | 2 1 | 1 2 | | 1 | | | | |
 | 1 2 | 1 1 | 2 1 | 1 2 | | 1 | | 1 2 | 1 2 1 | 2 2 | |
 | 1 2 | 1 1 | 2 1 | 1 2 | | 1 | | 1 2 1 | 2 1 2 1 | 2 2 | |
 | 1 2 | 1 1 | 2 1 | 1 2 | | 1 | | 1 2 1 2 | 1 2 1 | 1 | | 停
 ||: 1 1 | 2 1 2 | 1 1 | 2 1 2 | || 接基本节奏 2

Roll

 | 1 2 1 | 2 1 2 | 1 2 1 | 2 1 2 | | 1 2 1 | 2 1 2 | 1 2 1 | 2 1 2 | |
 | 1 2 1 | 2 1 2 | 1 2 1 | 2 1 2 | | 1 2 1 | 2 1 2 | 1 2 1 | 2 1 2 | |
 | 1 2 1 | 2 1 2 | 1 2 1 | 2 | | 1 2 1 2 | 1 2 | 1 2 | 1 2 | |
 | 1 2 | 1 1 | 2 1 | 1 2 | | 1 | | | | |
 | 1 2 | 1 1 | 2 1 | 1 2 | | 1 | | 1 2 | 1 2 1 | 2 2 | |
 | 1 2 | 1 1 | 2 1 | 1 2 | | 1 | | 1 2 1 | 2 1 2 1 | 2 2 | |
 | 1 2 | 1 1 | 2 1 | 1 2 | | 1 | | 1 2 1 2 | 1 2 1 | 1 | | 停
 ||: 1 1 | 2 1 | 1 1 | 2 1 | || 打鼓唱到清唱直到结尾